

③ SCALE: 1/2" = 1'-0"

Single Horizontal Electric Slide Door with Backup Casings and Return Jamb

Model EFD-SHES

Bottom Door Guide

Exterior Pull Handle with Interior Recessed Handle

- ① ELEVATION – SWEEP BOTTOM SLIDING DOOR (EXTERIOR)
- ② SECTION – SWEEP BOTTOM SLIDING DOOR
- ③ JAMB – SWEEP BOTTOM SLIDING DOOR



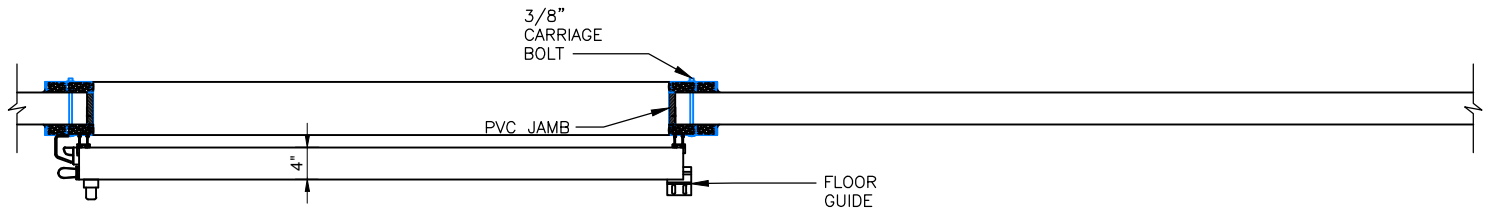
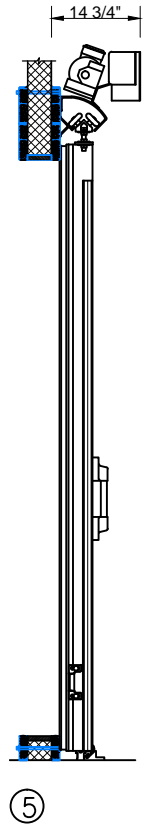
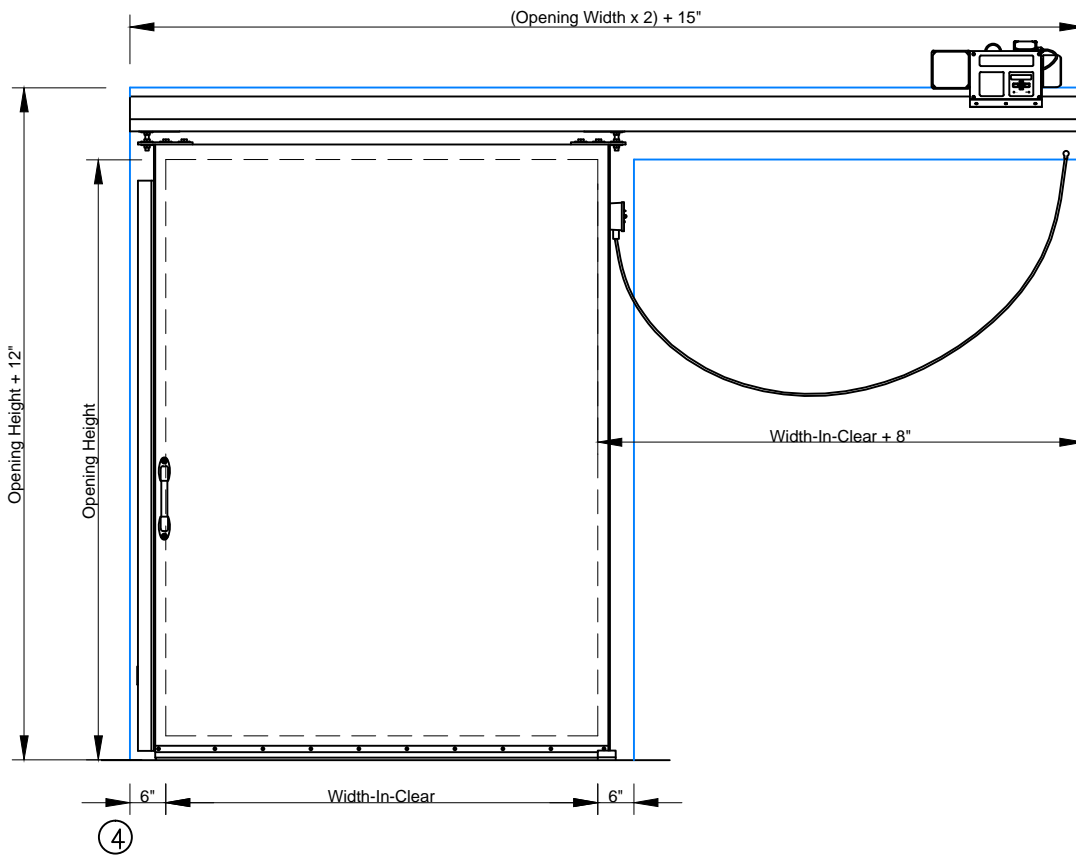

Single Horizontal Electric Slide Door with Backup Casings and Return Jambes

Model EFD-SHES

Bottom Door Guide

Exterior Pull Handle with Interior Recessed Handle

- ④ ELEVATION – HIGH SILL STEP OVER SLIDING DOOR (EXTERIOR)
- ⑤ SECTION – HIGH SILL STEP OVER SLIDING DOOR
- ⑥ JAMB – HIGH SILL STEP OVER SLIDING DOOR



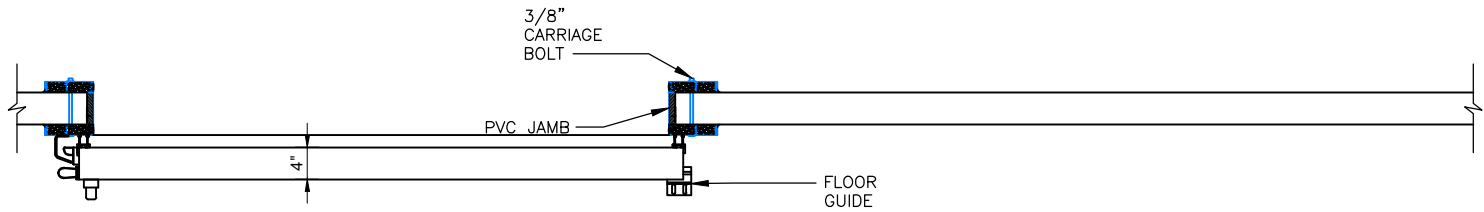
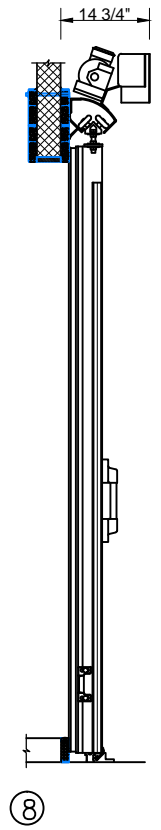
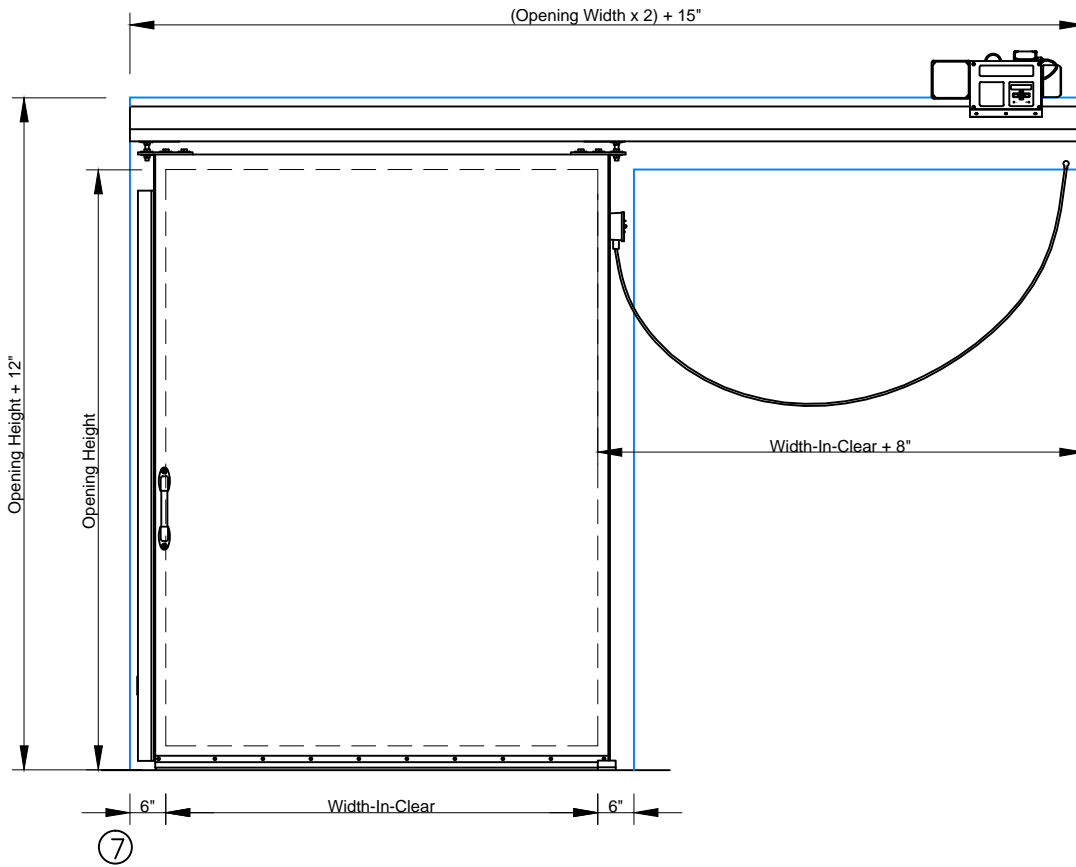

⑨ SCALE:  $1/2" = 1'-0"$

Single Horizontal Electric Slide Door with Backup Casings and Return Jambs

Model EFD-SHES

Bottom Door Guide

Exterior Pull Handle with Interior Recessed Handle

- ⑦ ELEVATION - HIGH SILL SLIDING DOOR (EXTERIOR)
- ⑧ SECTION - HIGH SILL SLIDING DOOR
- ⑨ JAMB - HIGH SILL SLIDING DOOR



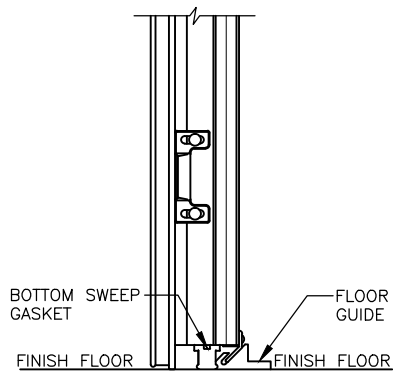

⑩ SCALE: 1" = 1'-0"

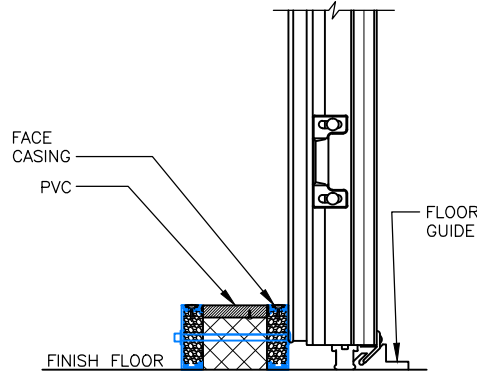

⑪ SCALE: 1" = 1'-0"

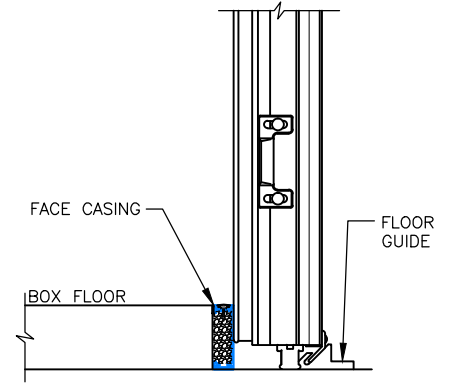

⑫ SCALE: 1" = 1'-0"

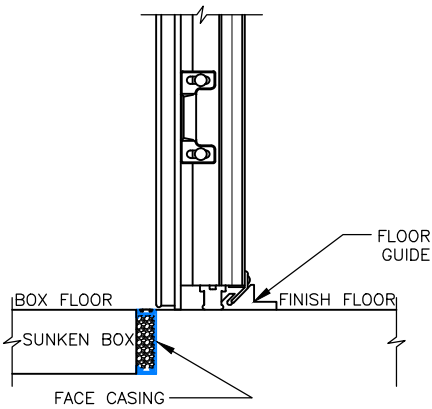

⑬ SCALE: 1" = 1'-0"

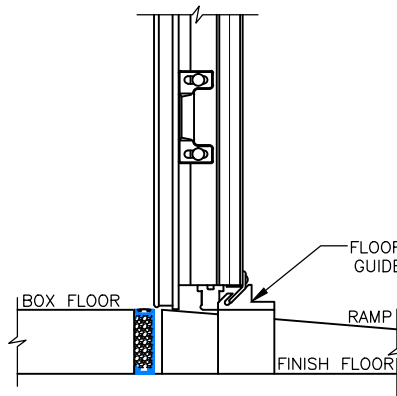

⑭ SCALE: 1" = 1'-0"

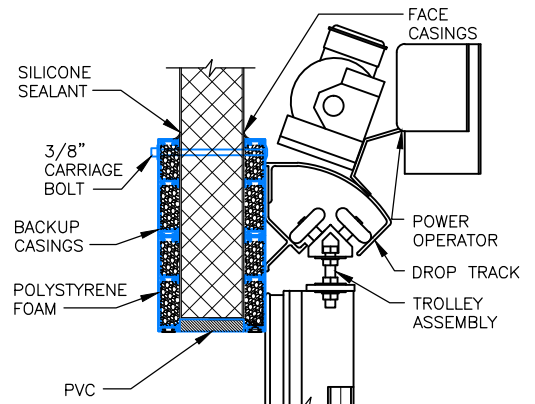

⑮ SCALE: 1" = 1'-0"

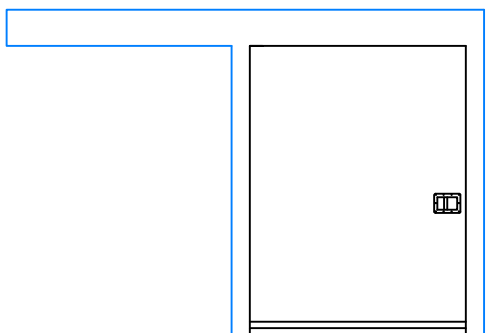

⑯ SCALE: 3/16" = 1'-0"

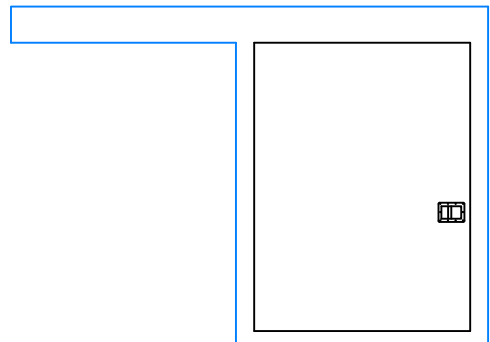

⑰ SCALE: 3/16" = 1'-0"

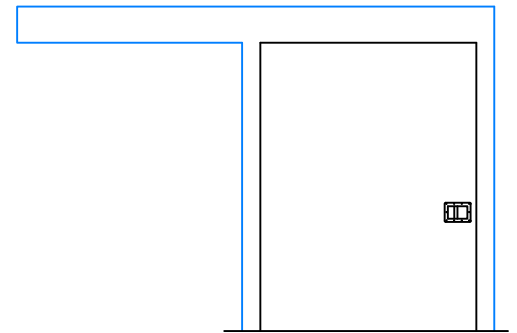

⑱ SCALE: 3/16" = 1'-0"

**Single Horizontal Electric Slide Door with Backup Casings and Return Jambs**

**Model EFD-SHES**

Bottom Door Guide

Exterior Pull Handle with Interior Recessed Handle

- ⑩ SILL DETAIL – SWEEP BOTTOM
- ⑪ SILL DETAIL – HIGH SILL STEP OVER
- ⑫ SILL DETAIL – HIGH SILL
- ⑬ SILL DETAIL – HIGH SILL WITH SUNKEN BOX FLOOR
- ⑭ SILL DETAIL – HIGH SILL WITH RAMP
- ⑮ HEAD – SLIDING DOOR – INSULATED METAL PANEL
- ⑯ ELEVATION – SWEEP BOTTOM SLIDING DOOR (INTERIOR)
- ⑰ ELEVATION – HIGH SILL STEP OVER SLIDING DOOR (INTERIOR)
- ⑱ ELEVATION – HIGH SILL SLIDING DOOR (INTERIOR)

